



YOOJIN

MULTI-LAYER PIPE LINE

■ Model:YJP-3-60/90/60

Item	Description	
Applicable resin	HDPE, PP, PPC.	
Application of pipe	Drainage pipe, Water pipe, Gas pipe	
Range of pipe Size	φ 40~ φ 200	
Extruder	φ 60/ φ 90/ φ 60, Three (3) layer extruder	
Name of Parts	Number of Screw	φ 90×1pc, φ 60×2pcs
	Main motor	75KW×1, 22KW×2 inverter
	Type of die	3-layer spiral die block
	Size of die	φ 150mm
	Vacuum calibrator	φ 600×6000L×1 unit
	Spray cooling bath	6000mm ×2 unit
	Haul-off unit	Two (2)point caterpillars
	Rotary Saw cutting unit	φ 600×2.4T
	Chip collector	Induction motor 2P×1.5KW
	Pneumatic Stacker	1000mm×6000mm×1400mm
	Capacity	150kgs-300kgs/hr

MAIN PRODUCTS

- Multi-layer blown film extrusion lines.
- Multi-layer pipe extrusion lines.
- Flat sheet blown extrusion lines.
- Flat-Yarn manufacturing lines.
- Mono-filament manufacturing lines.
- Extrusion laminators.
- PP band manufacturing machines.
- Super Henschel mixer & cooling mixer.
- Scrap recycling/granulating machines.
- Other Plastic processing machinery.

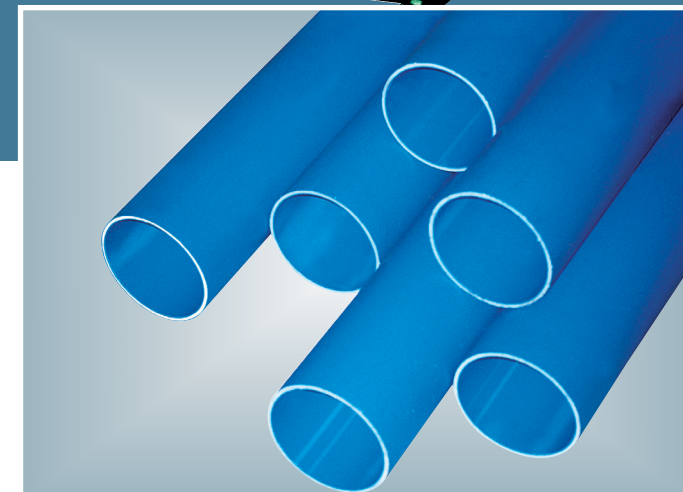
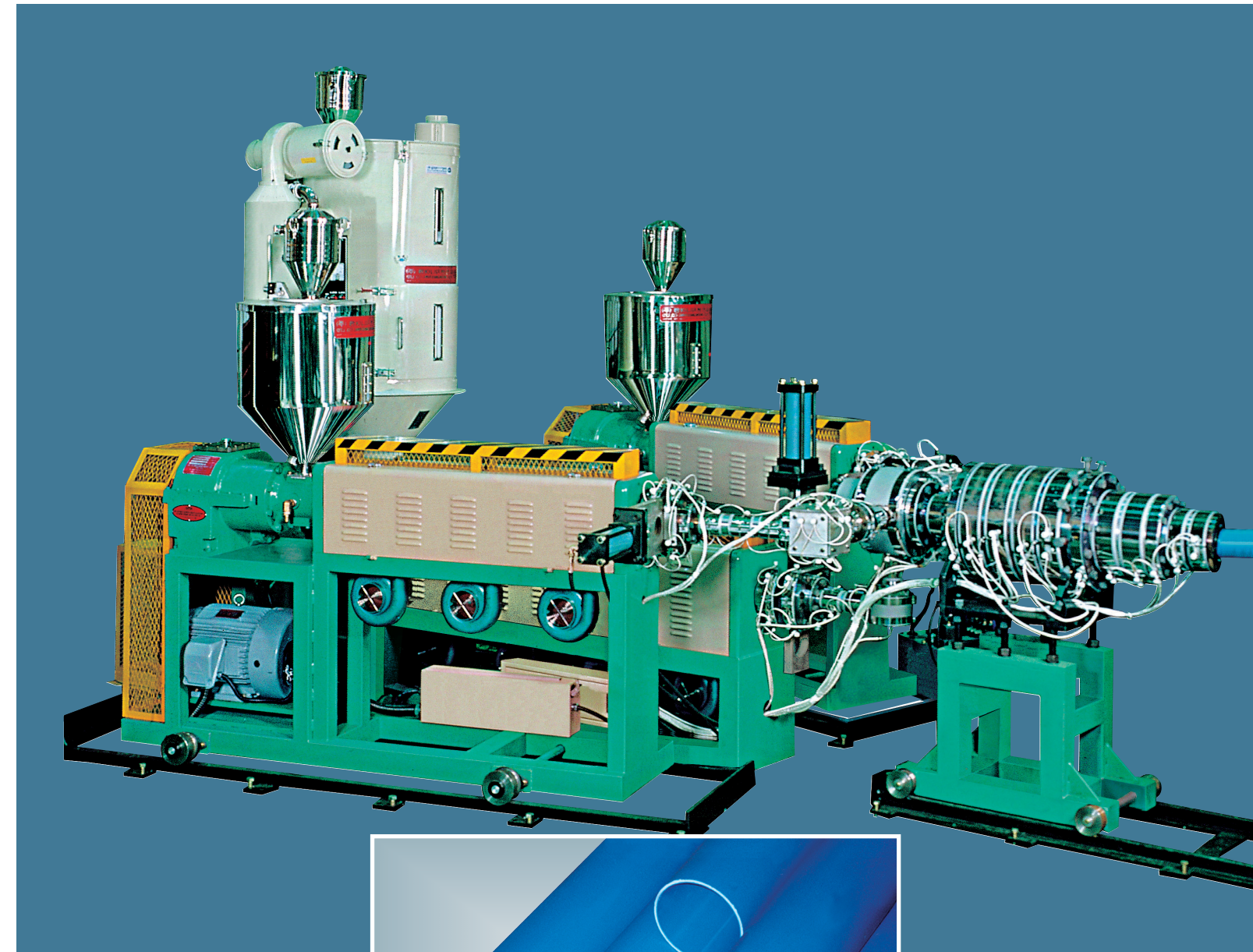



YOOJIN ENGINEERING CO., LTD.

Head office & Factory
 1377-14 Jeongwang-dong, Shihung-si,
 (Sihwa Industrial Complex 3-Ra-615)
 Kyunggi-do, 429-450, Korea.
 TEL : 82-31-499-7234 FAX : 82-31-499-7239
 http : //www.yoojin-eng.co.kr
 E-mail : yoojinmc@chollian.net / yoojinmc@yoojin-eng.co.kr

YJP-3-90/60/60

HIGHLIGHTS ...

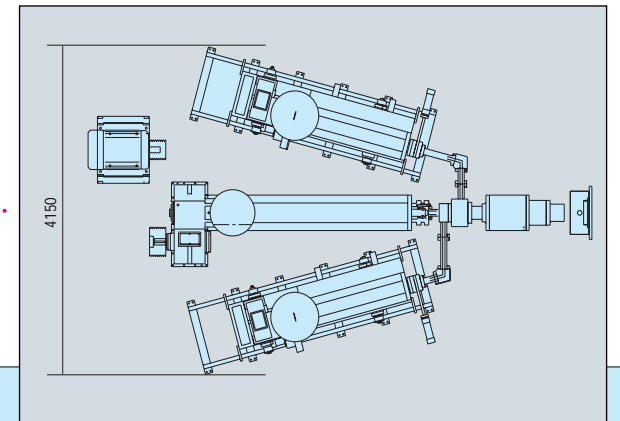
MULTI-LAYER PIPE LINE



Layout YJP-3-90/60/60 Line

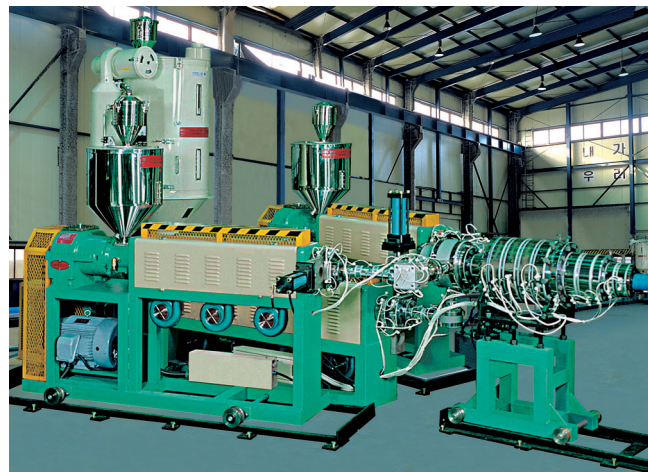
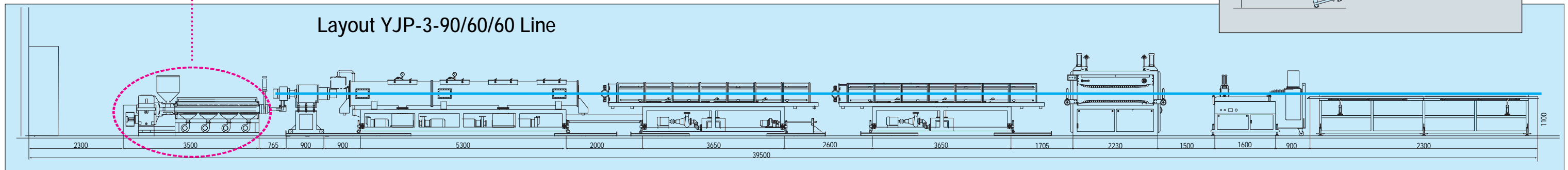

EXTRUDERS & DIE



VACUUM CALIBRATOR



SPRAY COOLING BATH



HAUL-OFF UNIT



SAW CUTTING UNIT